

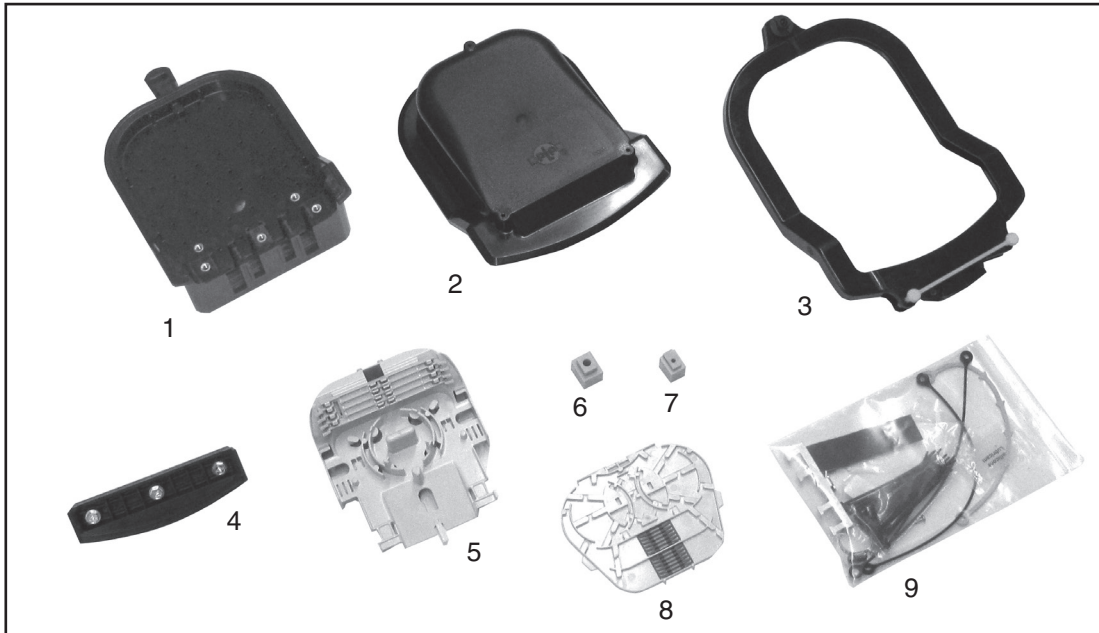

COYOTE® DTC8 for Drop Cable Distribution

Be sure to read and completely understand this procedure before applying product. Be sure to select the proper PREFORMED™ product before application.



NOMENCLATURE

- 1. Base (1)
- 2. Cover (1)
- 3. Collar (1)
- 4. End Plate (1)
- 5. Drop Cable Distribution Organizer (1)

- 6. Large Grommets (4)
- 7. Small Grommet (4)
- 8. Splice Tray (0 - 4)
- 9. Small Parts Bag (1)

TOOLS REQUIRED

- 3/8" & 7/16" sockets or can wrench
- Fiber optic cable opening tools
- 1/4" Nut driver or screwdriver
- Phillips Head Screwdriver
- Snips

COYOTE® DTC8 Mounting Bracket Kits		
Catalog Number	Description	Kit Image
8004104	COYOTE DTC8 Pole/Wall Mount Bracket Kit	
8004105	COYOTE DTC8 Cable Storage Bracket Kit	
8004108	COYOTE DTC8 Pedestal Mounting Bracket Kit	
8004111	COYOTE DTC 4/6 Aerial Mounting Bracket Kit – Strand Applications	
8004112	COYOTE DTC 4/6 Aerial Mounting Bracket Kit – ADSS Applications	
80812501	Cover Lanyard Kit	

Feed and Branch Cable Preparation

Step #1 Measure each cable to determine the diameter of the cable and select the proper grommet(s) for your application.

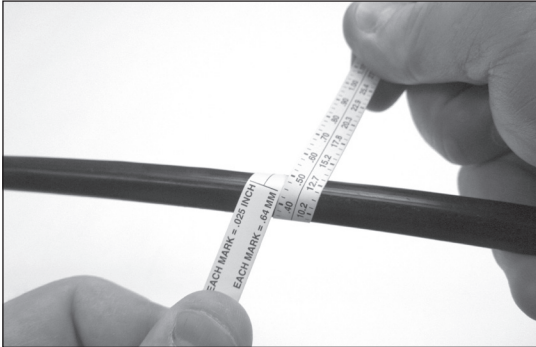

Large Grommet Selection		Cable Diameter Range
A		SOLID / PLUG
B		.170" - .220" (4.3 - 5.6 mm) ROUND CABLES
C		.220" - .270" (5.6 - 6.9 mm) ROUND CABLES
D		.270" - .320" (6.9 - 8.1 mm) ROUND CABLES
E		.320" - .370" (8.1 - 9.4 mm) ROUND CABLES
F		.370" - .420" (9.4 - 10.7 mm) ROUND CABLES
G		.420" - .470" (10.7 - 11.9 mm) ROUND CABLES
H		.470" - .550" (11.9 - 14.0 mm) ROUND CABLES
J		.156" - .170" (4.0 mm - 4.3 mm) ROUND DROP CABLES
K		.093" - .125" (2.4 - 3.2 mm) ROUND DROP CABLES
L		FLAT DROP CABLES ONLY

Step #2 Insert each cut cable in the appropriate grommet. If the cable is expressing fiber, slit the grommets as shown below, before installing the grommets over the cable. (See Step 1 for slit locations on each grommet).

Cut Cables

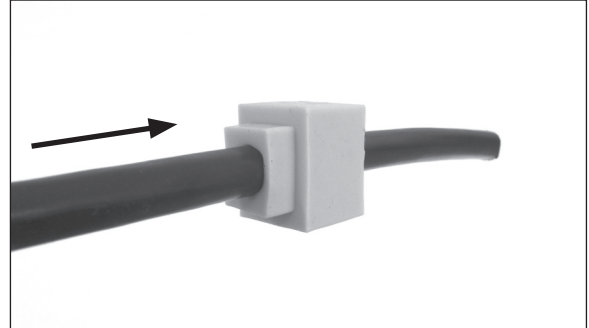

Expressed Cables

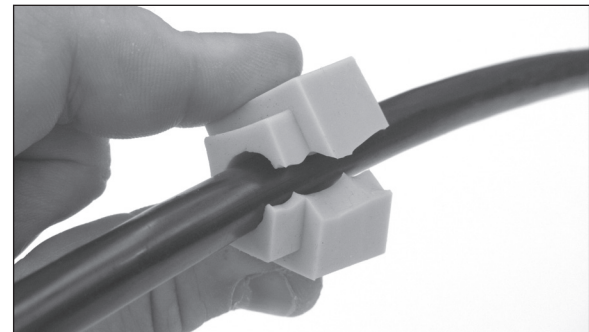
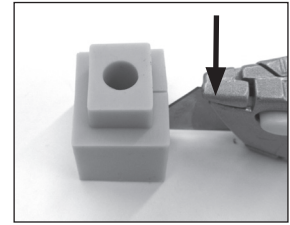
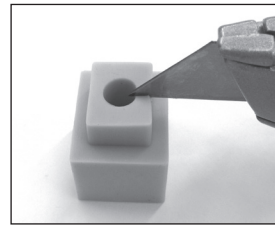

Step #3 If the cable has a tracer wire or is a Figure 8 style cable, remove the ground wire or tracer wire from the portion of the cable that will be positioned in the grommet and insert the cable into the grommet.

Cable with Tracer Wire

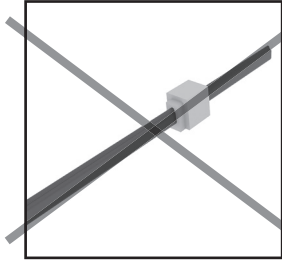

NOT CORRECT INSTALLATION

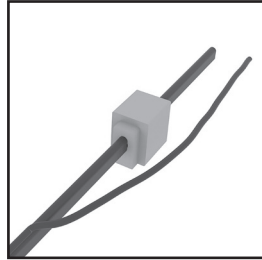

CORRECT INSTALLATION

Figure 8 Style Cable

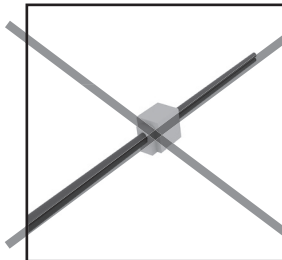

NOT CORRECT INSTALLATION

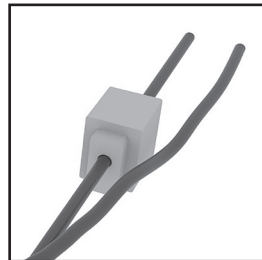

CORRECT INSTALLATION

Step #4 Prepare loose tube/buffer tube cables(s) for cut applications.

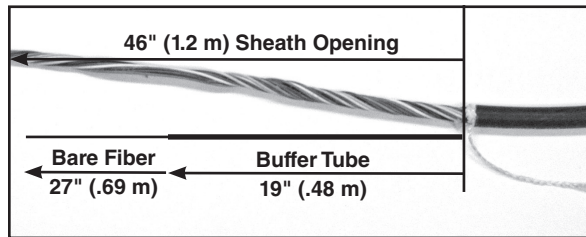

Sheath Opening Breakdown for Feed and Branch Cable	
Buffer Tube Length	19" (.48 m)
Bare Fiber Length	27" (.69 m)
Total Sheath Opening	46" (1.2 m)

PLP Tip: Leave about 5" (13 cm) of the strength member to trim later.

Cable Sheath Opening for Applications where Fiber is Dedicated to the Splice Point

Step #5 Prepare loose tube/buffer tube or cable(s) for mid sheath applications (Express/Balloon/Ring Cut).

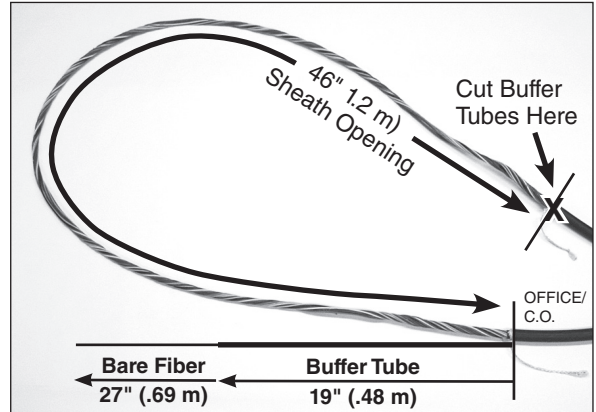

For Applications Where Fiber is Dedicated to the Splice Point	
Buffer Tube Length	19" (.48 m)
Bare Fiber Length	27" (.69 m)
Total Sheath Opening	46" (1.2 m)
Fiber/Buffer Tube Cut Location	X (see image above)

PLP Tip: Leave about 5" (13 cm) of the strength member to trim later.

Step #6 If the cable contains Kevlar®, braid roughly 3" (7.2 cm) of the Kevlar.

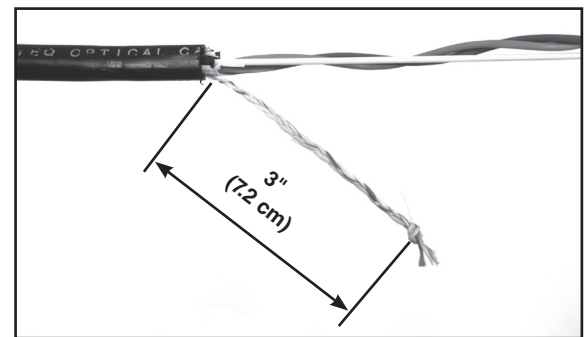

Step #7 Trim the cable strength member 2.5" (6.4 cm) away from the cable sheath opening.

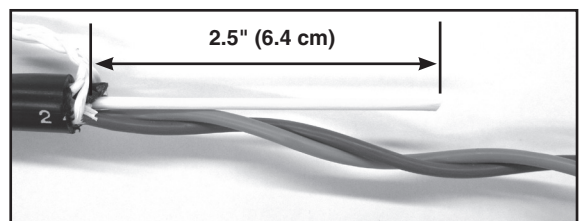

Attaching Feed Cables to Organizer

Step #8 Install the strength member retention caps to the bottom of the organizer with the self-tapping screws that are provided.

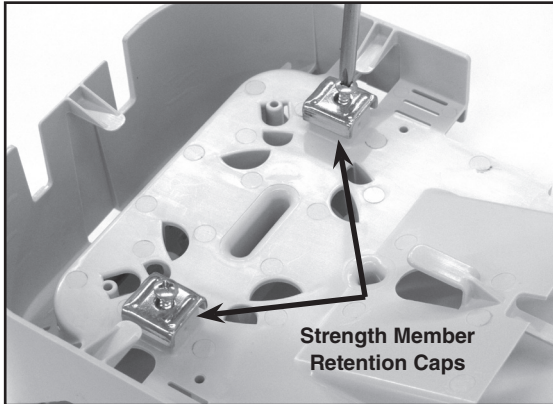

Step #9 If the cable contains Kevlar®, wrap the braided Kevlar around the screw under the retention cap. Position the cable strength members under the cap and tighten down the screw to secure them.

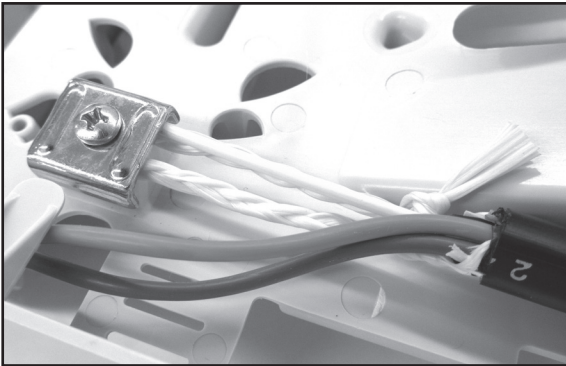

Step #10 Secure the cables to the organizer with hose clamps as shown below.

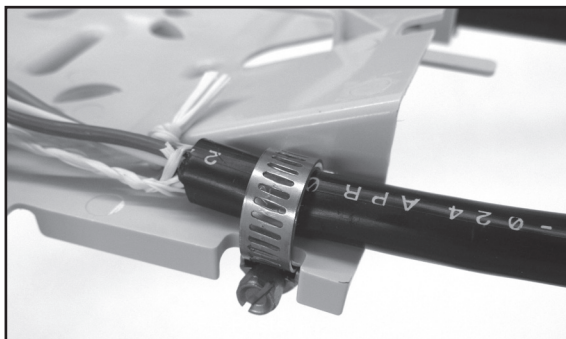

Buffer Tube Routing for Feed Cables

Step #11 Route any expressed buffer tubes under the tabs located on the bottom of the organizer.

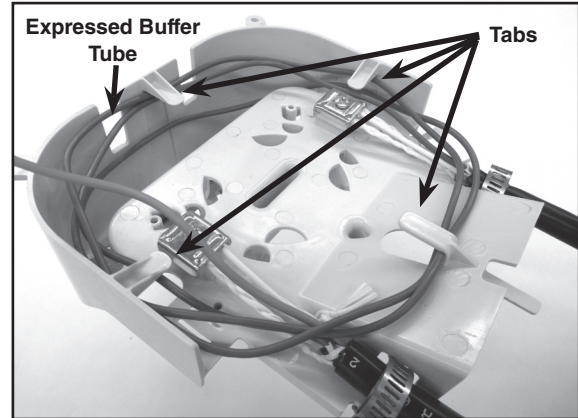

Step #12 Route any buffer tubes with fibers to be spliced under the tabs once before routing them to the top of the organizer.

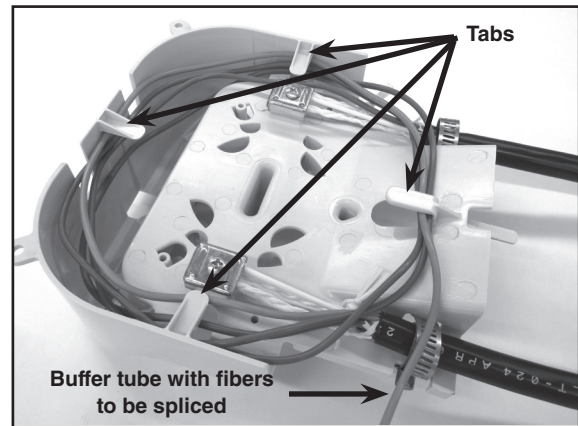

Step #13 Wrap the buffer tube(s) with felt and secure the buffer tube(s) to the organizer with 2 tie wraps.

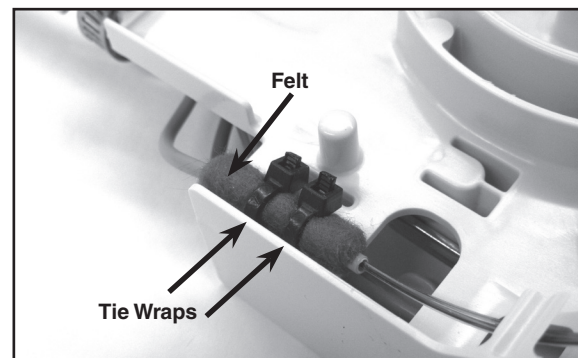

Standard Splice Tray Installation

Step #14 Place the first splice tray at the bottom of the hinge plate and position the splice tray perpendicular to the organizer as shown below.

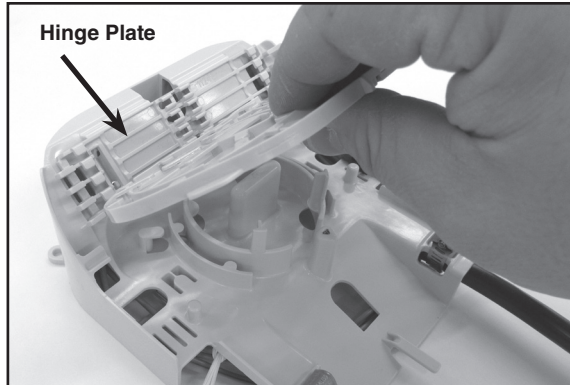

Step #15 Insert the hinge portion of the splice tray into the receiving portion of the hinge plate.



Reverse Splice Tray Installation

Step #16 Remove the hinge plate from the organizer by pushing in the spring tab of the hinge plate located underneath the organizer.

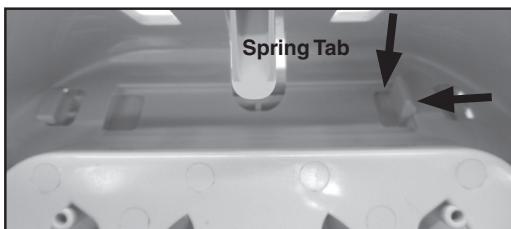

Step #17 Rotate the hinge plate 180 degrees and re-install the hinge plate into the organizer.

NOTE: Fiber routing tab should be facing up

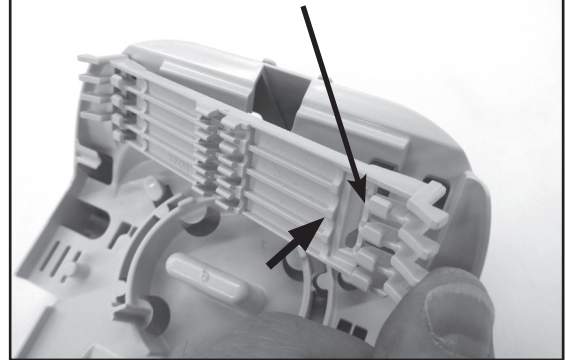

Step #18 Place the first splice tray at the bottom of the hinge plate and position the splice tray perpendicular to the organizer as shown below. Make sure that the back side of the splice tray is facing up.

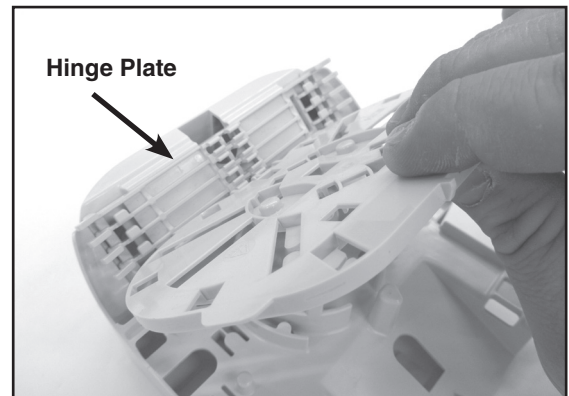

Step #19 Insert the hinge portion of the splice tray into the receiving portion of the hinge plate.

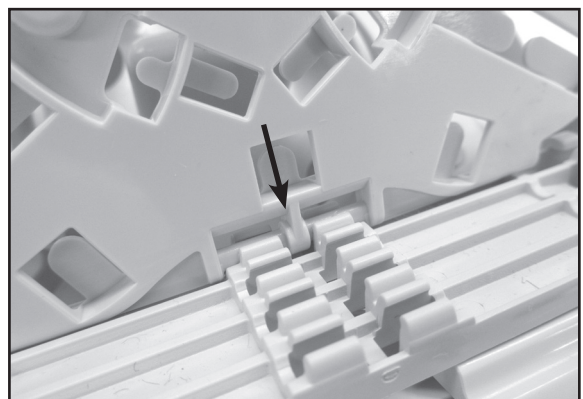

Fiber Routing for Feed Fibers

Step #20 Route feed fibers to be spliced up to the splice tray(s) and store them on the tray(s).

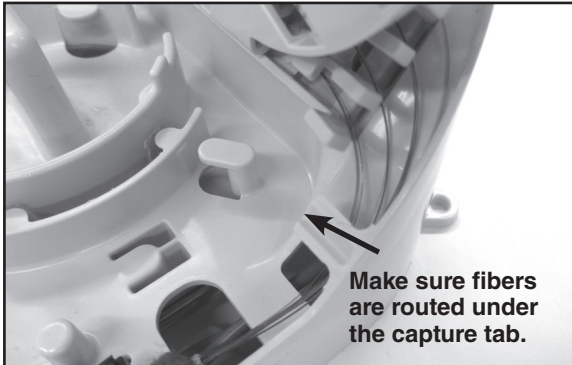

Step #21 Route dark fibers from the feed buffer tube(s) in the dark fiber storage area of the organizer.

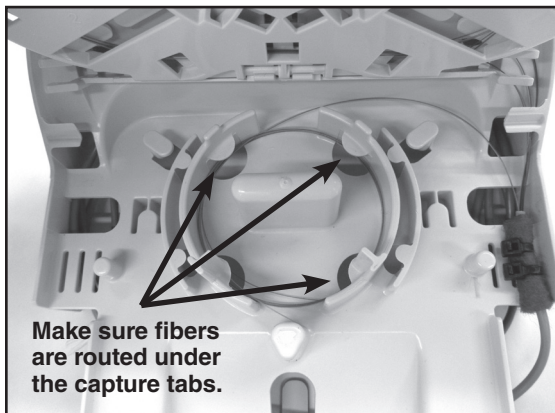

Organizer Installation

Step #22 Position the grommets 1-1/4" (3.2 cm) away from the organizer.

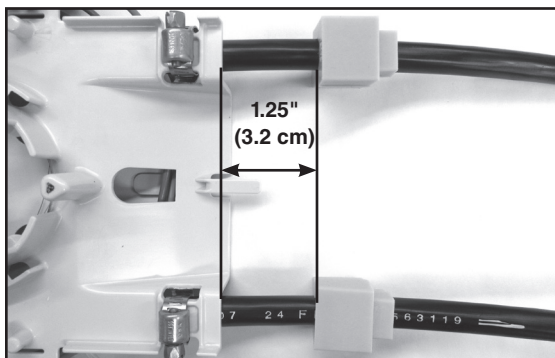

Step #23 Apply a light coating of lubricant to all outer surfaces of each grommet.

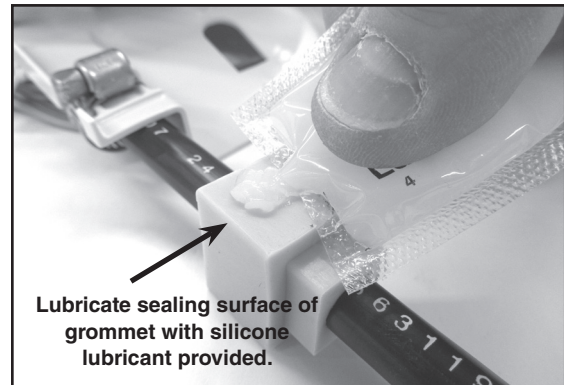

Step #24 Insert the grommets in the outside grommet pockets of the closure as shown below.

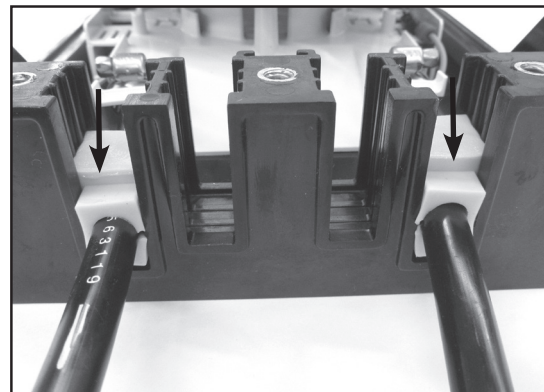

IMPORTANT NOTE:

The large "L" grommet can not be used in the bottom outer two positions when it is slit

Unslit "L" Grommets

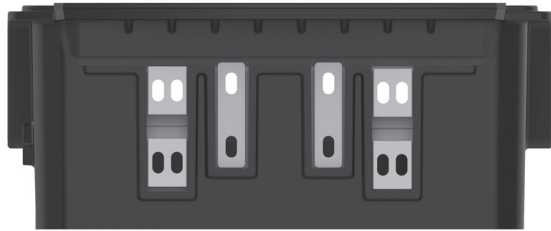

Slit "L" Grommets

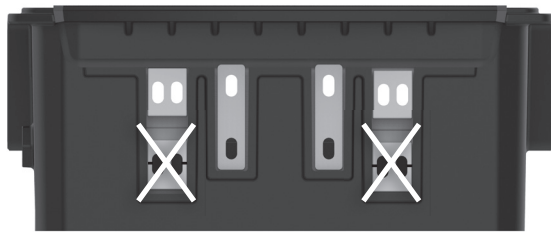

Step #25 Secure the organizer to the base with the self-tapping screws that are provided.

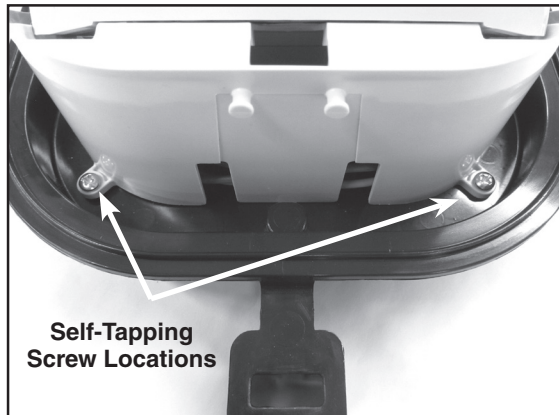

Self-Tapping
Screw Locations

Drop Cable Preparation

Step #26 Measure each cable to determine the diameter of the cable and select the proper grommet(s) for your application.



Slit Locations

Small Grommet Selection		Cable Diameter Range
A		SOLID / PLUG
B		.170" - .200" (4.3 - 5.1 mm) ROUND CABLES
C		.250" - .350" (6.4 - 8.9 mm) ROUND CABLES
D		.156" - .170" (4.0 mm - 4.3 mm) ROUND CABLES
E		.093" - .125" (2.4 - 3.2 mm) ROUND CABLES
F		FLAT DROP CABLE
G		.350" - .400" (8.9 - 10.2 mm) ROUND CABLES
Large Grommet Selection		Cable Diameter Range
J		.156" - .170" (4.0 mm - 4.3 mm) ROUND DROP CABLES
K		.093" - .125" (2.4 mm - 3.2 mm) ROUND DROP CABLES
L		FLAT DROP CABLES ONLY

Step #27 Insert the drop cables through the grommets as shown.

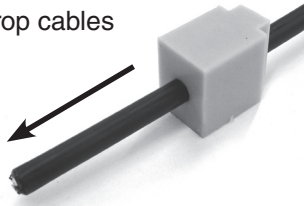

Step #28 If the cable has a tracer wire or is a figure 8 style cable, remove the tracer wire or messenger wire from the portion of the cable that will be positioned in the grommet and insert the cable into the grommet.

Cable with Tracer Wire

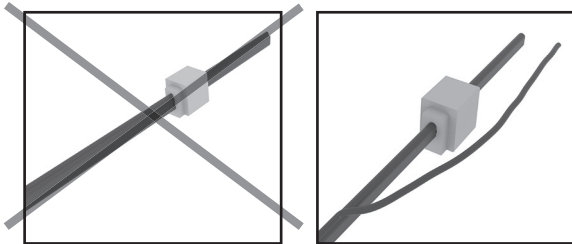

NOT CORRECT
INSTALLATION

CORRECT
INSTALLATION

Figure 8 Style Cable

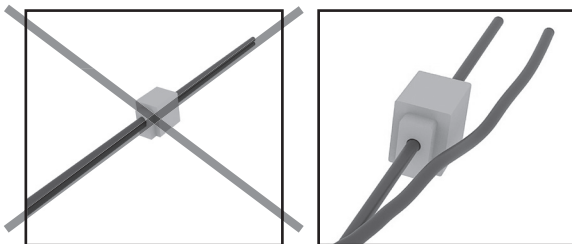

NOT CORRECT
INSTALLATION

CORRECT
INSTALLATION

Step #29 Measure, mark, and remove the cable sheath for cut cable applications as shown below.

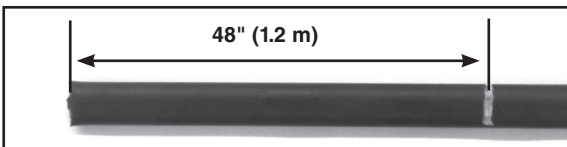

Step #30 Trim the strength members flush with the sheath opening.

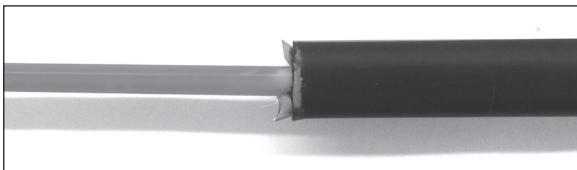

Step #31 Mark and remove the buffer tube 1/8" (.32 cm) away from the sheath opening.

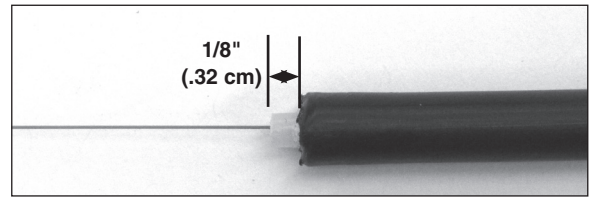

Step #32 Position the grommets roughly 1" (2.5 cm) away from the sheath opening.

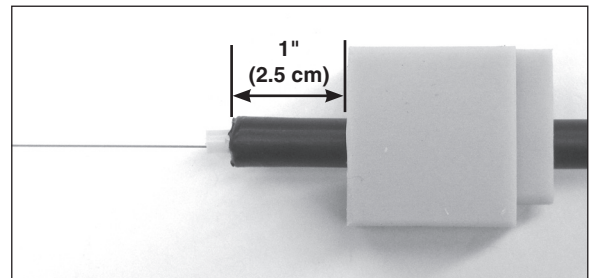

Step #33 Wrap the felt around the drop cable as shown below.

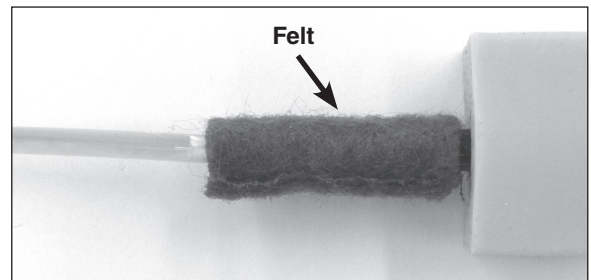

Step #34 Install plug(s) in any grommet that will not be used.

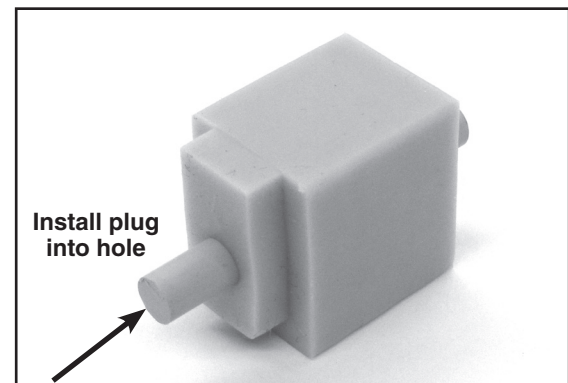

Step #35 Apply a light coating of lubricant to all outer surfaces of each grommet.

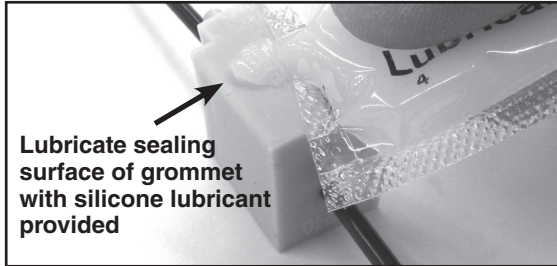

Lubricate sealing surface of grommet with silicone lubricant provided

Step #36 Install the bottom layer of small grommets in the inside grommet pockets of the closure as shown below.

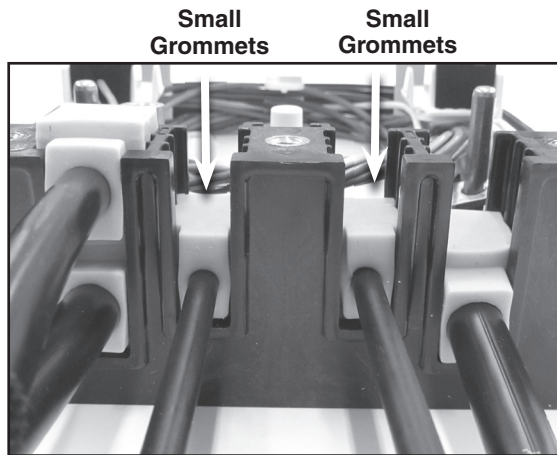

IMPORTANT NOTE: When installing the small grommets, position them in the pockets as shown below.

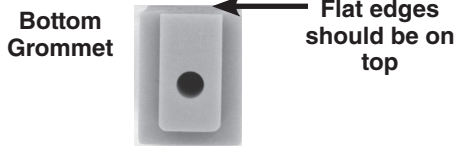

Step #37 Install the two position cable restraint bracket in the slot of the base as shown below. Use a cable tie wrap to secure the drop cable(s) to the restraint bracket.

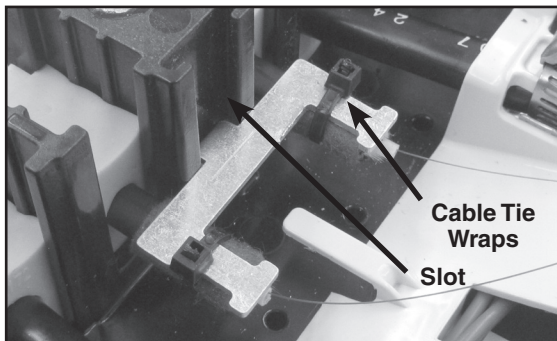

Step #38 Install the top layer of grommets into the closure. Insert the large grommets in the outside grommet pockets and the small grommets in the inside grommet pockets of the closure as shown below.

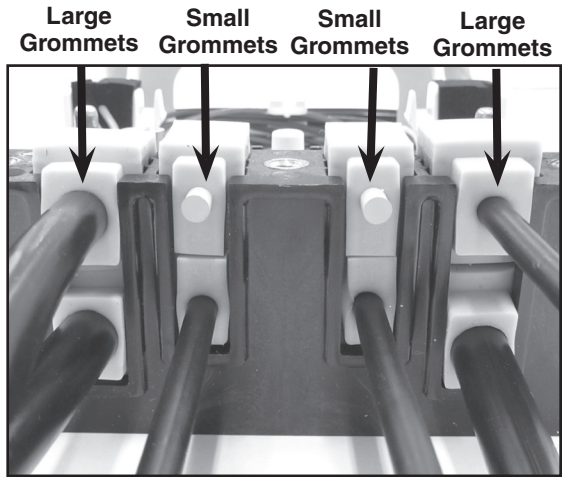

Step #39 Install the four position cable restraint bracket in the slot of the base as shown below. Use a cable tie wrap(s) to secure the drop cable(s) to the restraint bracket.

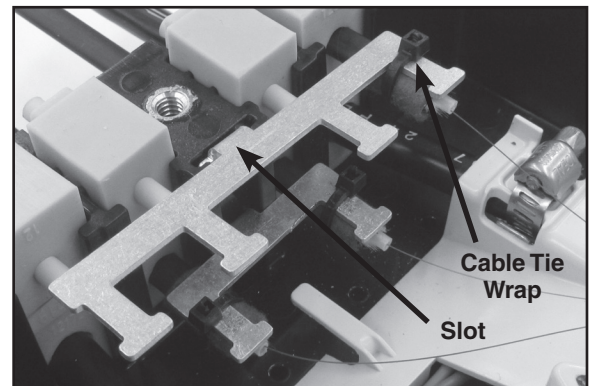

Step #40 Install the end plate and secure with the hex bolts.

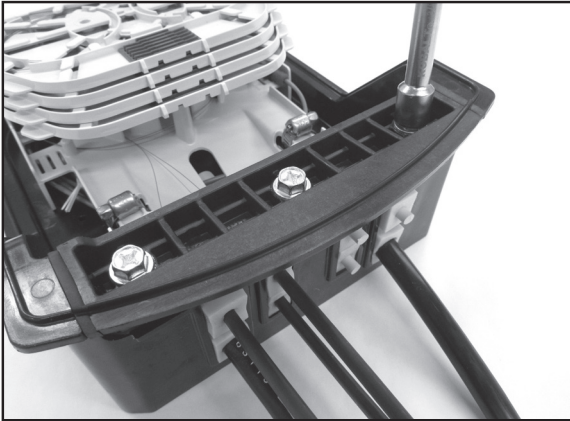

NOTE: Tighten bolts evenly by hand. DO NOT USE POWER TOOLS TO INSTALL THE COVER.

NOTE: When using a can wrench, nut driver, or Phillips screwdriver, the installed torque is 35 to 40 in-lbs.

Fiber Routing for Drop Cables

Step #41 Route fibers from drop cables as shown below.

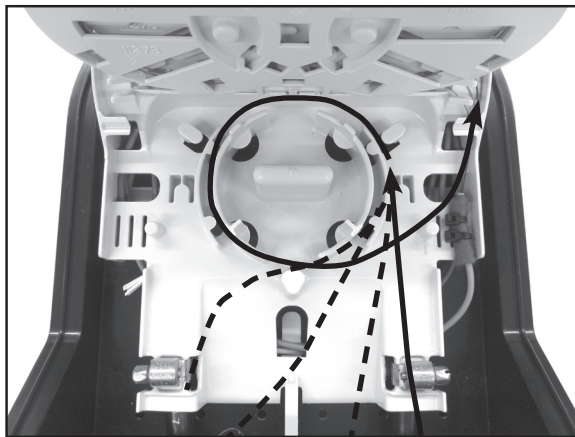
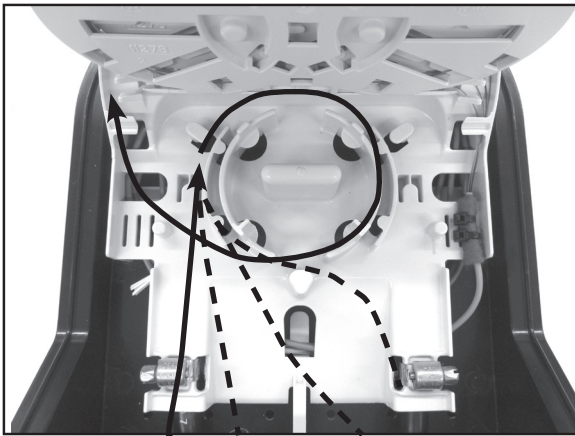

Fiber Routing on Splice Trays

Step #42 Route fibers on splice tray.

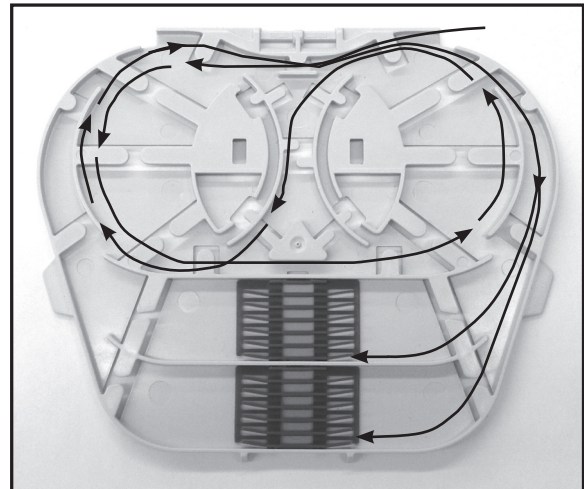
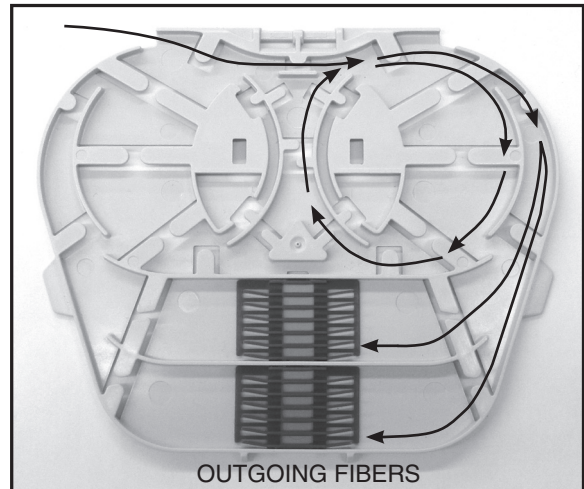
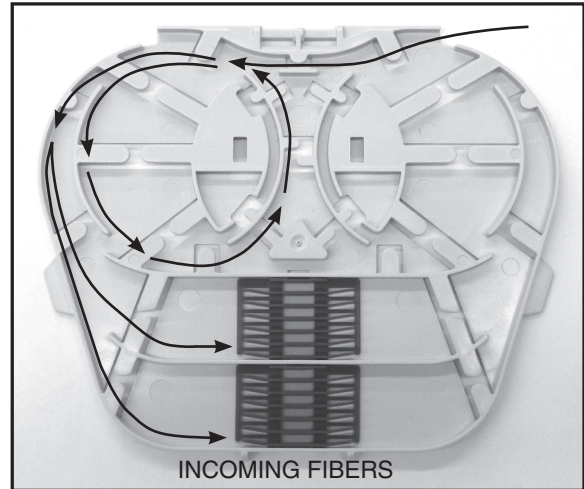

Step #43 Splice incoming fibers to outgoing fibers per your accepted company practice.

Supporting Splice Trays for Tray Access

Step #44 Install the ends of the tether onto the button heads on the organizer as shown.

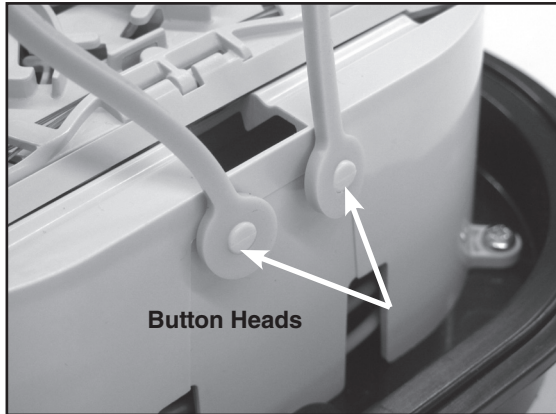

Step #45 Secure the trays in the upright position by wrapping the tether around the trays as shown.

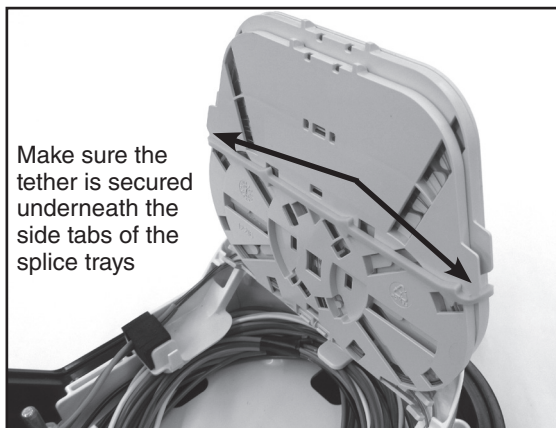

Securing Splice Trays

Step #46 Place the tray cover on the top tray. Make sure to verify that the correct side of the cover is installed on the tray.

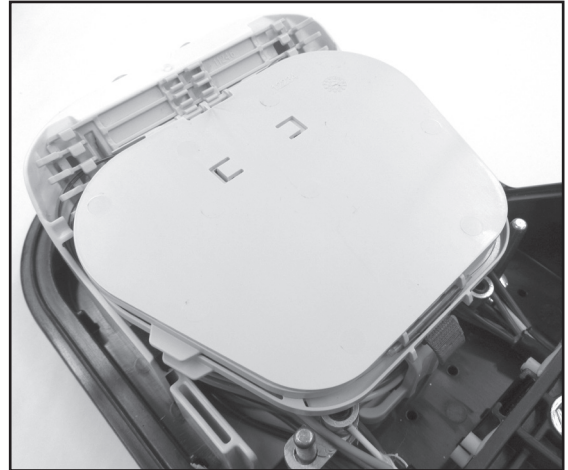

Step #47 Insert the eyelet of the tail end of the tether through the eyelet at the lead end of the tether. Slide the tether through the eyelet until first latch point passes through the eyelet as shown below.

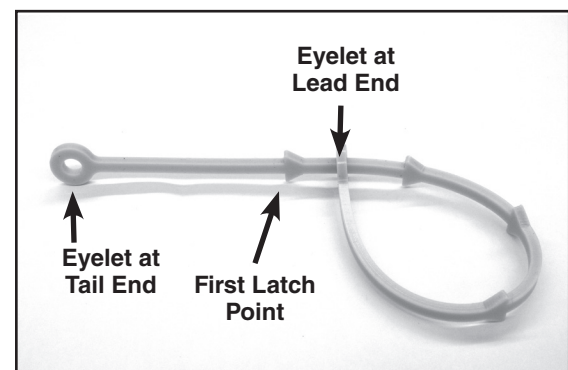

Step #48 Place the eyelet of the tail end of the tether over the retention tab of the organizer as shown below.

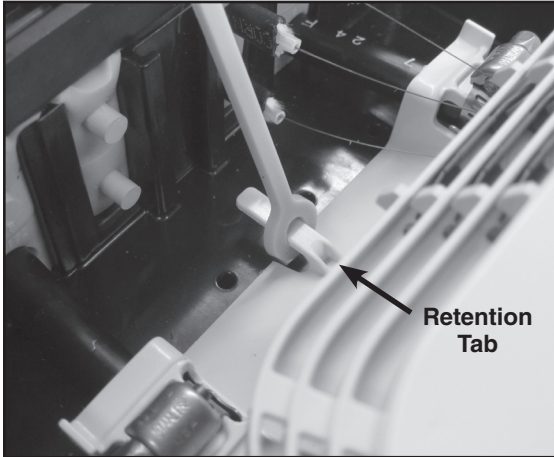

Step #49 Secure the splice trays by placing the loop of the tether over the button heads of the organizer as shown below.

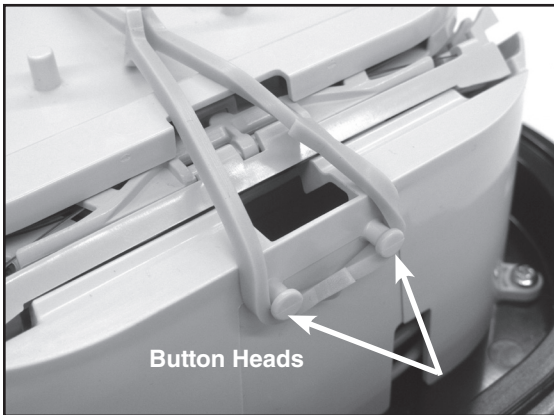

Cover Preparation and Installation

Step #50 Lubricate the sealing gasket of the cover with the silicone lubricant provided.



Step #51 Place the cover on the base.



Step #52 If the collar was removed from the base, re-insert the locking tab of the collar into the slot of the base.

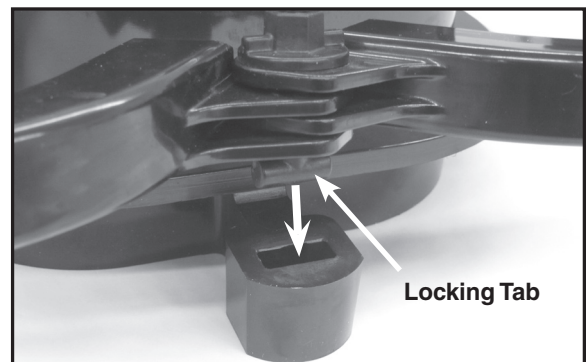

Step #53 Lock the collar to the base by twisting the collar fastener clockwise 90 degrees.



Step #55 Secure the collar latch and insert the pin into the latch.

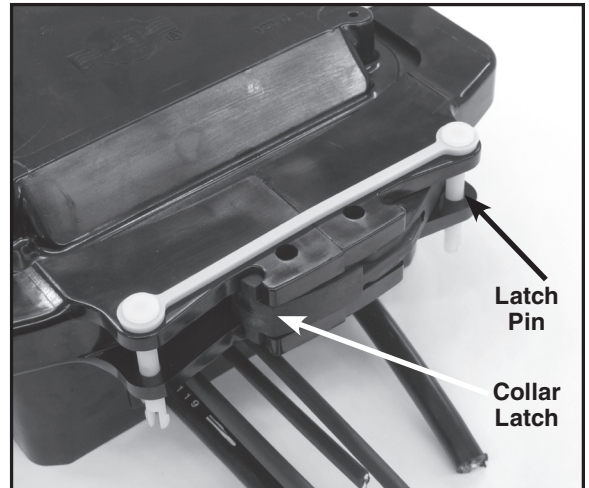

Step #54 Close the collar. Make sure that the lip of the base is secured under the collar when closing the collar.

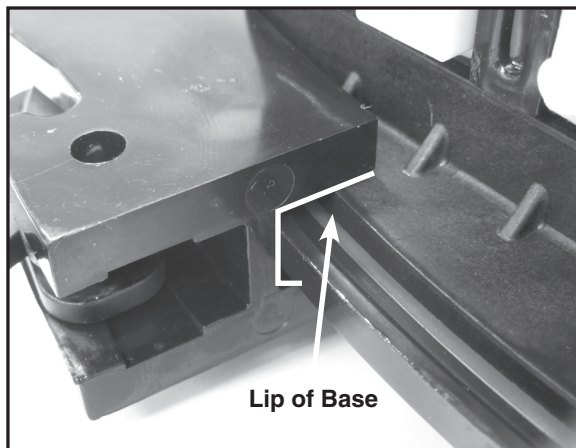
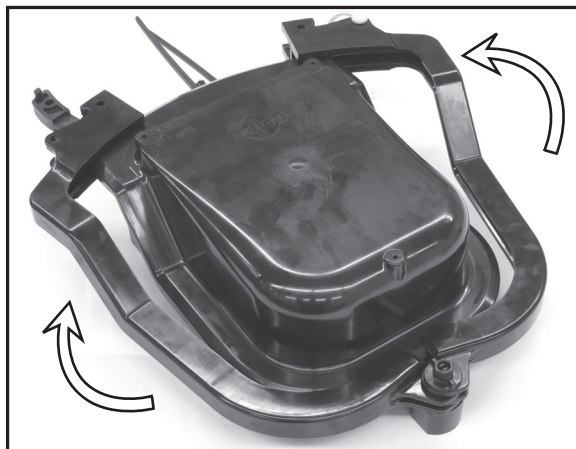

Cover Tether Option

Step #56 Secure the small hole end of the tether to the cover with the small self-tapping screw provided at one of the locations shown below.

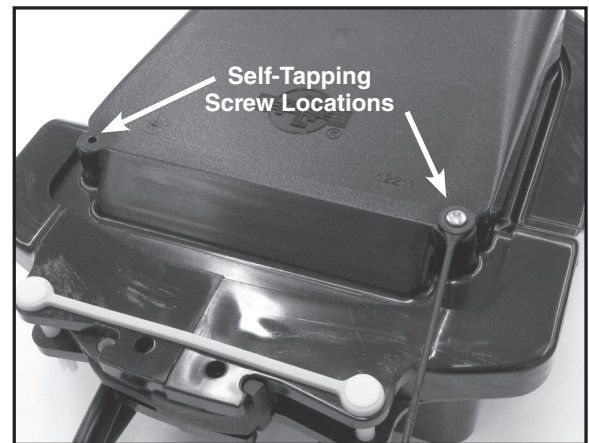

Step #57 Secure the large hole end of the tether to the back of the base with the large self-tapping screw provided at one of the locations, as shown below.

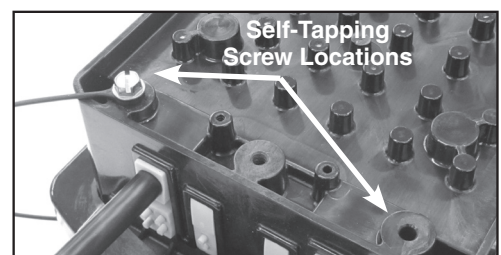

SAFETY CONSIDERATIONS

This application procedure is not intended to supersede any company construction or safety standards. This procedure is offered only to illustrate safe application for the individual. **FAILURE TO FOLLOW THESE PROCEDURES MAY RESULT IN PERSONAL INJURY OR DEATH.**

Do not modify this product under any circumstances.

This product is intended for use by trained technicians only. **This product should not be used by anyone who is not familiar with, and not trained to use it.**

When working in the area of energized lines, extra care should be taken to prevent accidental electrical contact.

For proper performance and personal safety, be sure to select the proper size PREFORMED™ product before application.

PREFORMED products are precision devices. To insure proper performance, they should be stored in cartons under cover and handled carefully.



PREFORMED LINE PRODUCTS

P.O. Box 91129, Cleveland, Ohio 44101 • 440.461.5200 • www.preformed.com • e-mail: inquiries@preformed.com
SP3268-2